

Oven, 90cm, 9 Function

Series 5 | Contemporary

Stainless Steel



With contemporary styling and clean lines in glass and steel, this built-in oven complements the style and elegance of any modern kitchen.

- One of the largest built-in ovens on the market providing 100L total capacity
- Nine functions including Pastry Bake, Roast and Fan Forced
- Features AeroTech – a technology that circulates heat evenly, ideal for multi shelf cooking

DIMENSIONS

Height	478mm
Width	895mm
Depth	564mm

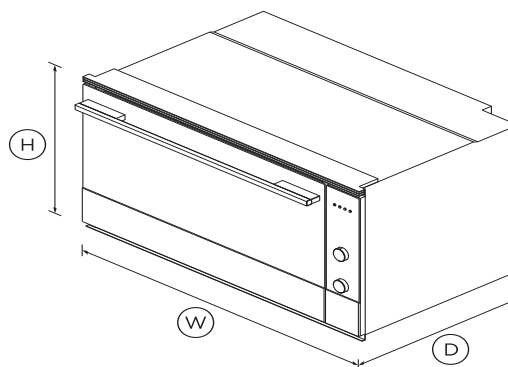

FEATURES & BENEFITS

Cooking flexibility

This built-in oven has nine functions with pre-set temperatures, including Bake, Pastry Bake and Fan Forced, allowing you to use a variety of cooking styles.

Pre-set oven functions

Oven functions are pre-set at the touch of a dial and brilliant lighting combined with a large viewing window reduce the need to open the oven door, providing perfect cooking results and improving energy efficiency.

Sized to suit

Designed for multi-shelf cooking, this is one of the largest built-in ovens on the market providing 100L total capacity. The wide cavity allows for both side by side and multi-shelf cooking.

Safe and sound

The CoolTouch door with triple glazing and cooling system is safe to touch from the outside, protecting your hands and the surrounding cabinetry.

Perfect results

This built-in oven features AeroTech – a technology that circulates heat evenly throughout the entire internal cavity to eliminate cold spots and ensure perfect, even results when cooking on multiple shelves.

Designed to match

With their premium handle styling and stainless steel finish, our built-in ovens are designed to match the rest of Fisher & Paykel's kitchen appliance family.

SPECIFICATIONS

Accessories

Grill rack	1 set
Roasting dish	1
Rotisserie set	1 sets

Capacity

Shelf positions	4
Total gross	100L

Cleaning

Acid resistant graphite enamel	•
Drop down grill element	•
Fat filter	•

- Removable oven door •
- Removable oven door inner •
- Removable shelf runners •

Controls

- Audio feedback •
- Automatic cooking/minute •
- Automatic pre-set •
- Celsius/Fahrenheit •
- Electronic clock •
- Precise electronic temperature •
- Rear light **2 x 20W (halogen)** •
- Sabbath mode •
- Turned stainless capacitive •
- Turned stainless dials with •

Functions

- Bake •
- Fan bake •
- Fan forced •
- Fan grill •
- Grill •
- Number of functions **9**
- Pastry Bake •
- Roast •
- Rotisserie •
- Warm •
- Warm •

Performance

- AeroTech™ technology •
- Automatic rapid pre-heat •
- Grill power **3600W**

Product dimensions

- Depth **564mm**
- Height **478mm**
- Width **895mm**

Safety

- Advanced cooling system •
- Balanced oven door •
- Control panel key lock •
- CoolTouch door •
- Non-tip shelves •

SKU **81941**

TEST The product dimensions and specifications in this page apply to the specific product and model. Under our policy of continuous improvement, these dimensions and specifications may change at any time. You should therefore check with Fisher & Paykel's Customer Care Centre to ensure this page correctly describes the model currently available. ? Fisher & Paykel Appliances Ltd 2020

Other product downloads available at fisherpaykel.com

- [↓](#) User Guide
- [↓](#) Service & Warranty Booklet
- [↓](#) Installation Guide



A PEACE OF MIND SALE

24 Hours 7 Days a Week Customer Support

T 1300 650 590 Wwww.fisherpaykel.com